

# Ulti Roll Air

## HIGH VALUE ENVIRONMENT CONTROL DOOR SYSTEM



The Ulti Roll Air is a premium performance PVC curtain door, with integrated air curtain for enhanced environmental control combined with high speed. Where project timeframes allow, this door can be configured in optimum specification for any application. This specialist door delivers exceptional value, even when a demanding set of criteria applies.

### Versatile

Where it is necessary to separate two high traffic areas with differing temperatures and humidity, the Ulti Roll Air's lateral ventilation system guarantees this environmental separation. Furthermore, due to its compact design, the Ulti Roll Air can be easily incorporated into restricted building clearances. With multiple upgrade options including full stainless-steel and full width vision, it continues to provide value in unique applications that are well beyond the market standard.

### Ideal for use in

- Food Hygiene Facilities
- Airlocks
- Laboratories
- Warehouses
- Distribution centres
- Manufacturing facilities
- Printing companies
- Logistic companies
- Supermarkets
- Chilled areas
- Heated areas

### Speed Where it Matters

The Ulti Roll Air has a standard opening speed of up to 2.0m/second with options to increase up to 3.0m/second. These world class speeds ensure the door outperforms any approaching traffic, maximising productivity, decreasing energy usage, and minimising the chance of impact damage from forklifts.

### Crash Resistant

At the heart of the Ulti Roll Air design is the innovative curtain edge that firmly holds the curtain into the side guides. The Ulti Roll Air curtain is made of reinforced PVC, with a flexible weighted soft bottom edge. The edge of the curtain has continuous injection moulded profile that allows rapid movement within the self-lubricating polyethylene track. The soft bottom edge enhances safety because there are no metal parts within the curtain design therefore damage is kept to a minimum.

### Self Repair

If an accidental impact occurs, causing the door curtain to release from the retention guides, these guides allow the curtain to be easily restored, minimising downtime and service calls.

### Multi Industry Applications

The Ulti Roll Air outperforms traditional door types in every industry. It can be applied to harsh industrial environments through to high end laboratory airlocks. The Insulated Curtain option means this door can be used in chilled or heated areas, preventing condensation and retaining temperatures, and the high wind load rating makes it perfect for positive pressure environments.



## STANDARD COMPLIANCE

Water Permeability	Class 1	Wind Permeability	Class 4
Wind Loading	Up to Class 4 5000 x 5000 = Class 2	Safe Openings	Yes
Thermal Transmittance	6.02 W/m <sup>2</sup> k	Acoustic Rating	Rw= 175dB with an insulated curtain
Pressure Differential	Up to 50Pa		

## TECHNICAL SPECIFICATIONS

Application	Internal and External
Standard	4000mm H x 3500mm W
Minimum Size	600mm H x 500mm W
Maximum Size	8000mm H x 4500mm W
Opening Speed	Up to 2.0m/second – variable
Closing Speed	0.8m/second – variable
Operating Temperature	-20 to +50°C (-0°C requires insulated curtain + heated frame)

## STRUCTURE

Frame Material	Galvanised steel frame structure with aluminium drive drum
Frame Colour	RAL9010

## SPACE REQUIREMENTS

### minimum clearances

Headroom	600mm
Sideroom	330mm (non-motor side), 530mm (motor side)

## CURTAIN

Material	900gr/m <sup>2</sup> Reinforced PVC Curtain
Curtain Colour	RAL6018 (standard), RAL1003, RAL1015, RAL2004, RAL3002, RAL5002, RAL5010, RAL5012, RAL6026, RAL7035, RAL7037, RAL7042, RAL8014, RAL8017, RAL9005, RAL9006, RAL9010
Vision Panels	1 row of large clear-vision panels

## MOTORISATION

Motor	IP54 rated 1.5kW Heavy Duty 3phase Motor Drive and electromagnetic brake – RH mounted
Motor Position	RH Side
Control Panel	IP54 rated Metal Control box with inverter frequency controller – RH mounted
Power Supply	400V; 3phase+N+E; 15Amp Rated adjacent to control box installed to right hand side
Air System Power Rating	1kw/ml clear height

## ACTIVATIONS

Manual	Push button and emergency stop button fitted to control box Manual Push Button
--------	--

## WARRANTY

12 Months or 100,000 Cycles  
\*Std Warranty terms and conditions apply

## DIMENSIONS

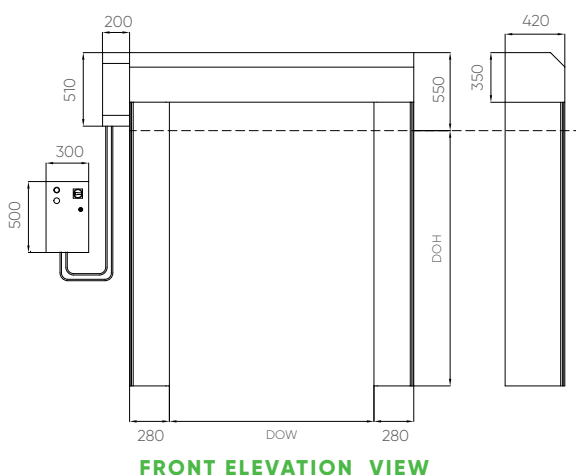

## SAFETY

Standard Inclusions	1 Set of Infrared PhotoCell Safety beams IP65 Soft PVC Bottom Edge LED Countdown Timer in Control box Reversing Sensor system for obstructions to door curtain
Emergency Egress	Manual hand crank

## STANDARD INCLUSIONS

Integrated Air Curtains	Re-feed slot in guides Encoder control Patented sliding system with high-density polyethylene, self-lubricating guides Perimeter seal system Performance rated to 1,000,000 cycles
-------------------------	--

## OPTIONAL FEATURES

Activations	All Ulti activation options
Motorisation	IP65 Rated 1.5kw Motor with Stainless Brake (for corrosive applications)
Control Panel	IP54 Corrosion Resistant AISI:304 Stainless Steel
Mounting Options	LH Power Supply, Custom Control Box Position, LH Control Box, LH Motor, Front Mount Motor reduces side room clearance to 125mm
Low Clearance Options	Compact Header Unit reduces headroom required to 500mm for doors <3000mm high
Power Supply	Single phase 240V 50Hz control box for door sizes <9m <sup>2</sup> Heavy duty single phase 240V 50Hz Control box (required for 9m <sup>2</sup> to 25m <sup>2</sup> door sizes)
Frame Material	Corrosion Resistant AISI:316 Stainless Steel Hygienic Stainless-Steel AISI:316, AISI:304 or AISI:441 Frame
Frame Colours	RAL3000, RAL5010, RAL7037, RAL9005, RAL9010
Curtain Design	Food Grade Curtain – FDA Approved in RAL9010 (1700gr/m <sup>2</sup> ) Heavy Duty Curtain (1300gr/m <sup>2</sup> ) – RAL1003, RAL1015, RAL2004, RAL3002, RAL5002, RAL5012, RAL6026, RAL7035, RAL7037, RAL7042, RAL9010 Custom Printed Curtain – Full curtain printing with photo/logo High-gloss embossed, flame retardant Translucent Reinforced PVC Curtain according to DIN 75 2000 – 900gr/m <sup>2</sup> ; light transmission: 35%; cold resistance: -30°C; heat resistance +70°C
Insulated Curtain	7mm 3.3W/m <sup>2</sup> k – RAL9010, RAL7035, RAL2004, RAL1003, RAL3002, RAL5002; clear vision panels n/a
Vision Panels	2 or 3 rows, custom rows and sizes available, Full Vision
Ventilated Panel	1, 2, or 3 rows, custom rows available
Safety	Virtual Vision Extended LED Countdown Timer 2000mm Tower Beam Safety Sensors IP67
Emergency Egress	Counter Balance Manual Release Manual Break-Out UPS Battery Backup (Single Phase) Side Emergency Exit
Other Features	90mm Guides for low side clearance Opening speed up to 3.0m/second – variable Heated Frame – 240V Heat tracing for Door Legs and Motor for Freezer Applications (additional 10Amp power supply isolator is required)

