

ulti group

Dok-Guardian Safety Barrier

Product Brochure

ULTIGROUP.CO.NZ



Dok-Guardian Safety Barrier



Protect Your Personnel and Equipment

Vacant loading docks create a dangerous 4' drop-off for dock personnel and material handling equipment. The brutal reality of this dangerous drop-off is often recognized only after it is too late. Rite-Hite has a full line of barrier products to make your loading docks safer. Dok-Guardian Safety Barriers help meet the requirements of OSHA Regulation 1910.23 regarding "protection for wall openings and holes."

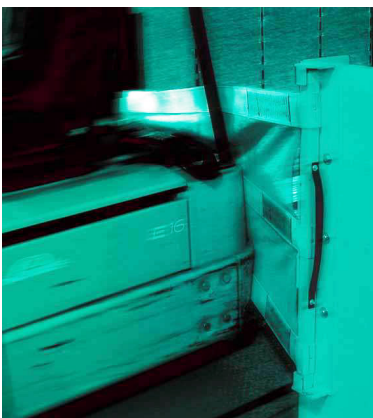

PREVENT DROP-OFF ACCIDENTS ON YOUR LOADING DOCKS

- Helps prevent fork trucks, pallet jacks and pedestrians from falling off the loading dock.
- Manually positioned barrier easily fits across openings up to 4.9m wide.
- Barrier heightens dock drop-off awareness.
- Warden™ guards provide excellent door track protection.

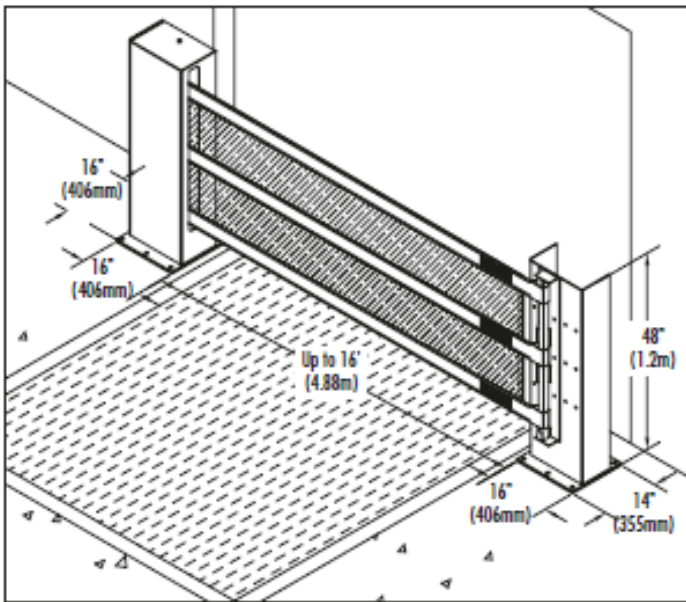

Barrier will stop a 4536 kg fork truck traveling up to 6.44 km/h with little or no damage to the safety barrier.

Specifications:

- 1.2m tall, 6.4mm steel Warden door guards (roller side and latching side)
- Warden guards to be painted safety yellow
- Utilizes 6 19mm x 133.4mm anchors each side (included)
- 15.9mm x 406mm x 406mm base plate (roller side)
- 15.9mm x 406mm x 355mm base plate (latching side)
- Curtain to be red PVC-coated fiberglass mesh with three heavy-duty polyester safety restraint straps
- Proper setback from the edge of the dock will be determined by the width of the Dok-Guardian
- 1-year warranty



Unique Warden "pocket" design



Dok-Guardian Light-Duty Safety Barrier



- Helps prevent fork trucks, pallet jacks and pedestrians from falling off the loading dock.
- Manually positioned barrier easily fits across openings up to 4.9m wide.
- Barrier heightens dock drop-off awareness.
- Warden™ guards provide excellent door track protection.

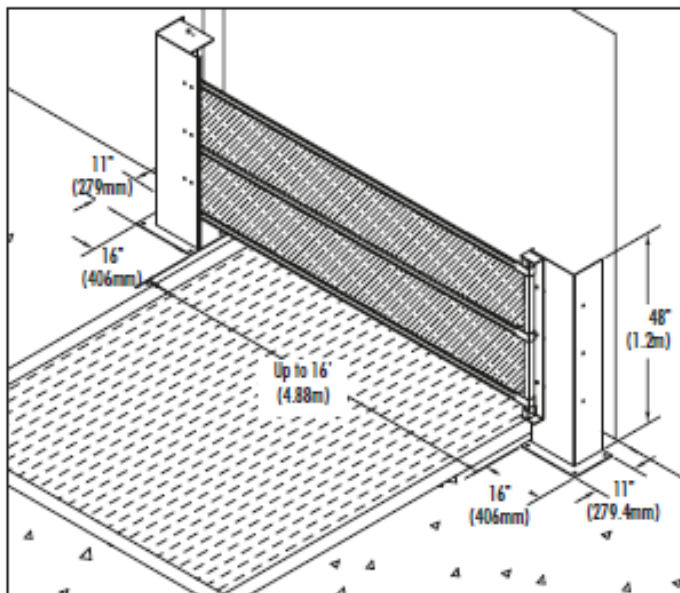

Specifications:

- 1.2m tall, 4.8mm steel Warden door guards (roller side and latching side)
- Warden guards to be painted safety yellow
- Utilizes 4 12.7mm x 133.4mm anchors each side (included)
- 6.4mm x 406mm x 279mm base plates (roller side and latching side)
- Curtain to be yellow PVC-coated fiberglass mesh with three polyester safety restraint straps
- Proper setback from the edge of the dock will be determined by the width of the dok guardian
- 1-year warranty

Fast, Easy Activation

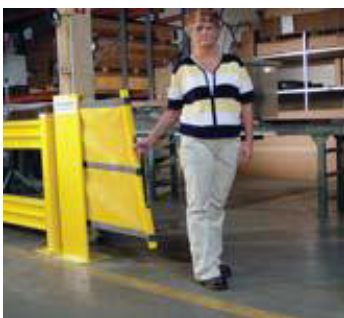

To activate, extend barrier across the opening



Latching system ensures safe, strong barrier protection.

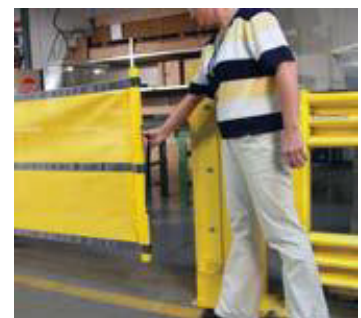

To store, remove barrier from the latching bracket and walk barrier to non-active position. Barrier automatically retracts.

Dok- Guardian Door Safety Barrier



Able to withstand only 300 to 800 lbs. of force, conventional sectional doors are no match for material handling equipment. The unique Door Dok-Guardian makes loading docks safer by preventing fork trucks from going through closed doors. The Door Dok-Guardian system also reduces door maintenance costs by eliminating most track and bottom panel damage.

- Loading dock drop-off protection for “closed door policy” facilities.
- Door Dok-Guardian will stop a 4536kg fork truck traveling up to 6.44km/h with little or no damage.
- Helps companies comply with American Institute of Baking (AIB) and Homeland Security Act.
- Break-away door brackets allow for easy reattachment after significant impact.
- Heavy-duty nylon strap mounted to bottom door panel automatically positions barrier with the travel of the door.
- Steel impact brackets attached to ends of strap slide into Warden™ door guards when the door is closed.
- Door track protection and impactable bottom panel for lower maintenance costs.
- The heavy-duty Warden door guards are 788mm high and constructed of 6.4mm steel to provide track protection when door is raised for loading/unloading.
- 1-year warranty.

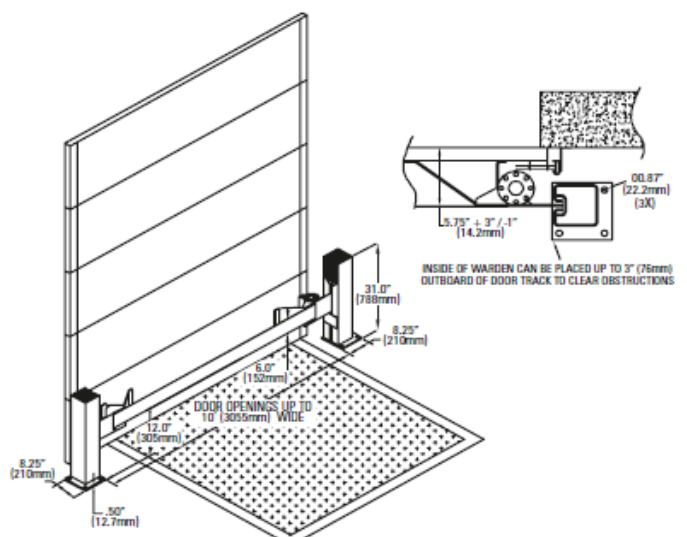
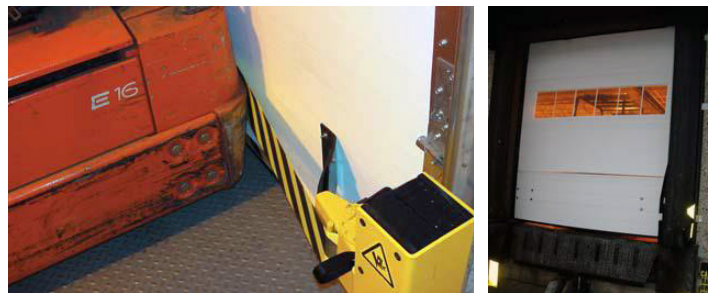



0800 807 753

105 Glover Road, Hawera, 4610
PO Box 340, Hawera, 4640

ULTIGROUP.CO.NZ